

## ELECTROPNEUMATIC TRANSDUCER

For Additional Information See EP 311/313 Data Sheet

### SPECIFICATIONS

**Accuracy\*:** ± 1% FS

**Maximum Supply Pressure:** 40 PSIG

**Pressure Differential:**  
0.1 PSIG (supply to branch)

**Supply Current:** 150 mA

**Supply Voltage:** 18-28 VAC/VDC

**Enclosure:** 18 Ga. C. R. Steel Chassis

**Finish:** Baked on enamel - PMS2GR88B

**EMC Conformance:** EN 55022, 55024, 61000-3-3,  
61000-4-2, 3, 4, 5, 6 & 11

**Compensated Temperature Range:** 25°F to 150°F (4°C to 65°C)

**T. C. Error:** ± 0.025%/°F (.03%/°C)

**Media Compatibility:** Clean dry air or any inert gas

**Port Connection:** 1/4" O.D. poly tubing

**Environmental:** 10 - 90% RH non-condensing

**Termination:** Screw terminal block

**Wire Size:** 12 Ga. max.

**Input Impedance:** 301 ohms (4-20 mA)  
10K ohms (0-5/0-10 VDC)

**Weight:** 1.0 lb. (.45 kg)

\* Includes non-linearity, hysteresis and non-repeatability

### ORDERING INFORMATION

MANUAL OVERRIDE	RANGE
311 Without override	315 3 - 15 psig
313 With override	020 0 to 20 psig

### INSTALLATION

**Inspection:** Inspect the package for damage. If damaged, notify the appropriate carrier immediately. If undamaged, open the package and inspect the device for obvious damage. Return damaged products.

#### Requirements:

- **Installer must be a qualified, experienced technician.**
- Tools (*not provided*):
  - Digital Volt-ohm Meter (DVM)
  - Appropriate screwdriver for mounting screws
  - Appropriate drill and drill bit for mounting screws
- Appropriate accessories
- Three #8 self-tapping mounting screws (not provided)

#### Warning:

- Do not use on oxygen service, in an explosive/hazardous environment, or with flammable/combustible media.
- Disconnect power supply before installation to prevent electrical shock and equipment damage.
- Make all connections in accordance with the job wiring diagram, and in accordance with national and local electrical codes. Use copper conductors only.

#### Caution:

- Use electrostatic discharge precautions (e.g., use of wrist straps) during installation and wiring to prevent equipment damage.
- Do not exceed ratings of the device.

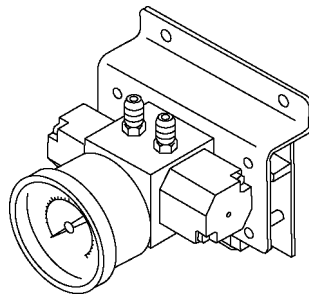

**Mounting:** The EP-311/313 must be mounted in an upright position so that the ports are facing upward and the gauge can be easily read.

1. Select the mounting location.
2. Mount the transducer on a vertical surface with three #8 self-tapping screws (not provided).
3. Pull wires through the bottom of the device and make necessary connections.
4. Make the necessary pneumatic connections.

**Wiring:** Use maximum 12 AWG wire for wiring terminals. Use flexible 1/4" O.D. poly tubing for main and branch pneumatic connections. Refer to **Figure 1** and **Figure 2** for wiring configurations, **Figure 3** for terminal location and designation, and **Figure 4** for dip switch settings.

#### CAUTION!

- **Main supply pressure must not exceed 40 PSIG.**
- A minimum of 6 to 10 feet (1.8 to 3.0m) of tubing should be between the unit and the actuator.
- For 24 VAC supply voltage, ensure that the hot and neutral are not reversed. If more than one unit is being powered from the same transformer, the hot and neutral should be the same for each unit.

**Note:** The gauge on the unit is for indication only. The transducer's calibration is more accurate than the accuracy of the gauge.

### TYPICAL APPLICATIONS (wiring diagrams)

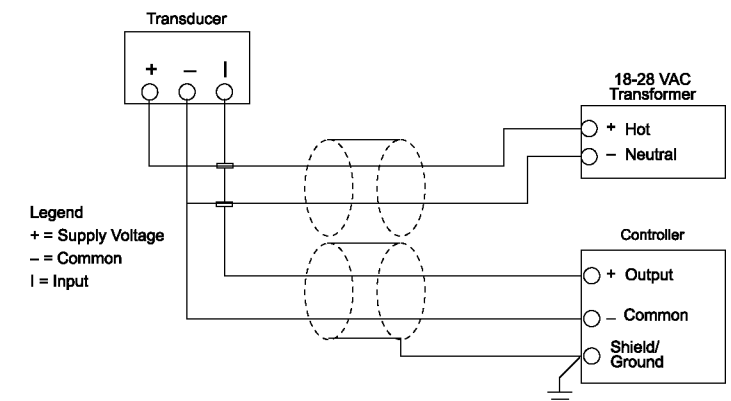

Figure 1 - Wiring Diagram for 24 VAC Supply Configuration

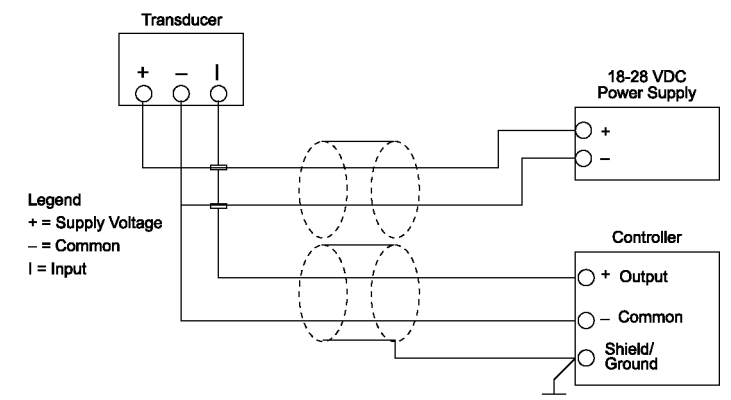

Figure 2 - Wiring Diagram for 24 VDC Supply Configuration

**Caution:** This product contains a half-wave rectifier power supply and must not be powered from transformers used to power other devices utilizing non-isolated full-wave rectifier power supplies.

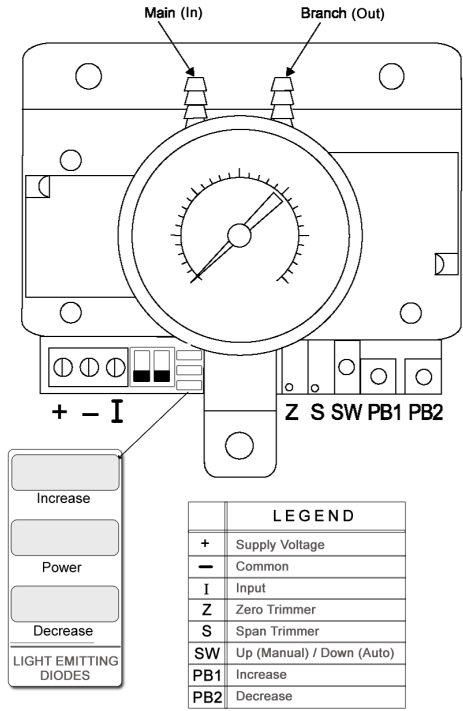
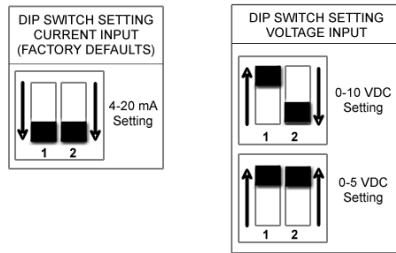

Figure 3 - Terminal Locations on EP-311/313

**Installation Adjustments:** The EP-311/313 is supplied from the factory set for 4-20 mA. To change the input configuration, adjust the Dip switch settings as illustrated in Figure 4 (below).

Figure 4  
Dip Switch Settings on EP-311/313



**CHECKOUT**

1. Verify that the unit is mounted in the current position.
2. Verify appropriate supply voltage.

**CAUTION:** NEVER connect 120 VAC to these transducers!

3. Verify appropriate input configuration.

**TRANSDUCER OPERATION**

*This is a rough functional check only.*

1. Adjust the input signal to obtain maximum output pressure for appropriate range.
2. Output should be 15 or 20 PSIG.
3. Adjust the input signal to obtain minimum output pressure.
4. Output should be 0 or 3 PSIG.

**CALIBRATION**

All units are factory calibrated to meet or exceed published specifications. If field adjustment is necessary, follow the instructions below.

1. Connect air to main port.
2. Connect branch port to an accurate gauge with a minimum 6 to 10 ft. (1.8 to 3.0m) of tubing.

3. Connect terminals + and - to the appropriate power source for this unit. The EP-311/313 can accept either 24 VAC or 24 VDC supply voltage. **The maximum supply voltage should not exceed 30 VAC/VDC.**
4. Apply low input signal to terminals - and I (0 VDC or 4 mA).
5. Adjust Z to obtain desired output low pressure.
6. Apply high input signal to terminals - and I (5/10 VDC or 20 mA).
7. Adjust S to obtain desired output high pressure.
8. Repeat Steps 4-7 until the unit is completely calibrated.

**MAINTENANCE / FIELD REPAIR**

Regular maintenance of the total system is recommended to assure sustained optimum performance. No field repair is possible. Replace suspect devices with a functional unit.

**WARRANTY**

See Data Sheet for additional information.

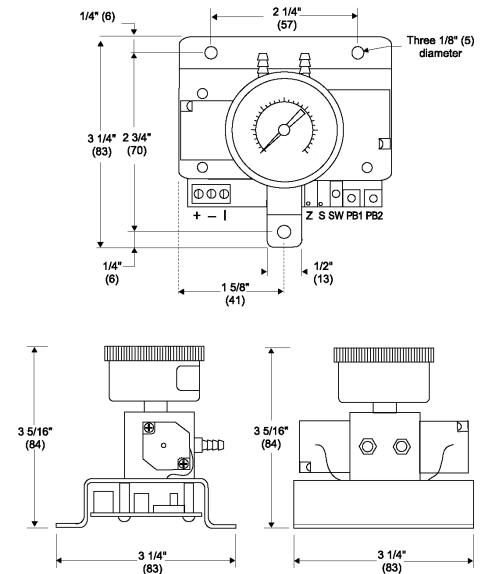

Figure 5 - EP-311/313 Electropneumatic Transducer Dimensions shown in inches and millimeters (mm)

For Technical / Application Assistance call your nearest office



MAMAC Systems, Inc., reserves the right to change any specifications without notice to improve performance, reliability, or function of our products.